

12 11 10 9 8 7 6 5 4 3 2 1

A

B

C

D

E

F

A

B

C

D

E

F

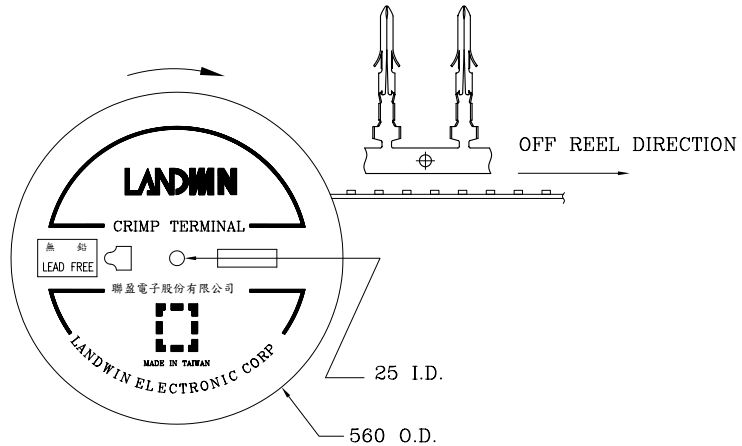

ROLL FORM PACKAGE

DESCRIPTION OF ORDER NO.:

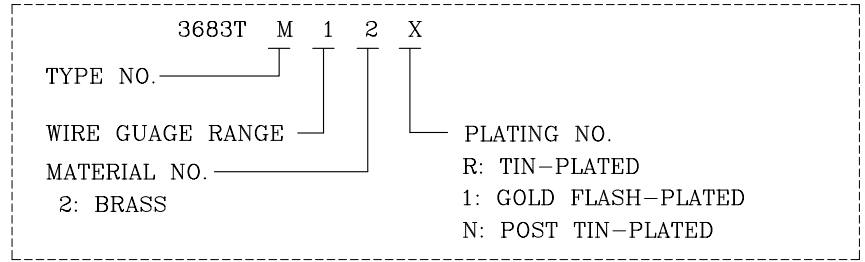

ORDER INFORMATION AND DIMENSION:

ORDER NO.	TERMINAL TYPE	WIRE GAUGE RANGE (AWG)	INSULATION DIAMETER	Q'TY/REEL
3683TM12X	CHAIN	#18 - #24	ø2.7 MAX.	6,000 PCS

NOTES:

- MATERIAL: BRASS
- USE WITH RECEPTACLE HOUSING:
<1> 3680M SERIES
- INFORMATION IN THIS DRAWING IS NOT CONSIDERED AS FINAL.

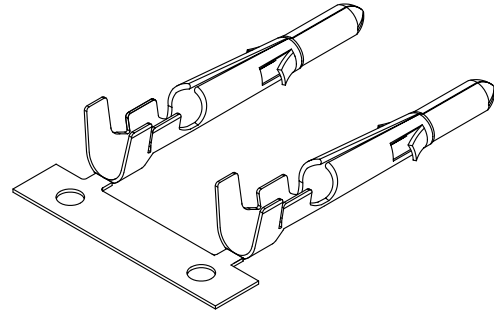
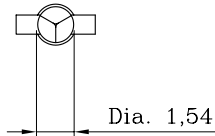
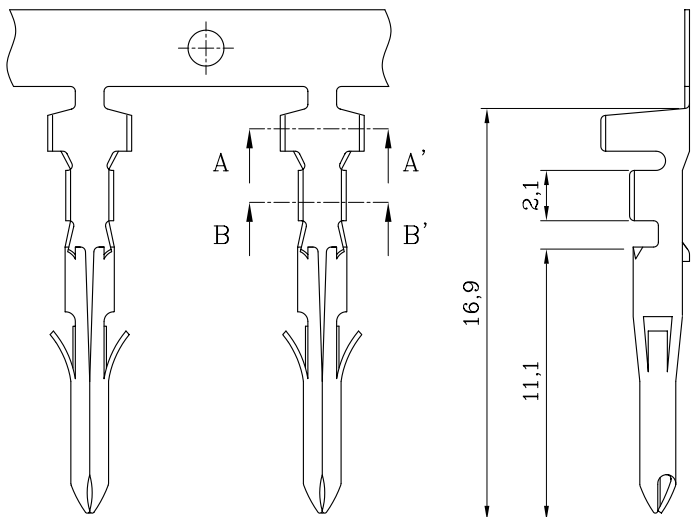

ISOMETRIC VIEW

		Sales Drawing			
<p>LANDWIN 聯盈電子股份有限公司 LANDWIN ELECTRONIC CORP.</p>					
GENERAL TOLERANCE:		PROJECTION	SCALE	UNIT	SHEET NO. REV
			FREE	MM	1 / 1 W1
		DRAWN	R.G.	DRAW NO.	
		CHECKED	J.L.Lin	(BQ) 3683TM12X	
		APPD	H.Y.Lin	TITLE:	
W1	NEW RELEASE	31-DEC-14'	ANGULAR ±3°	DATE 31-DEC-14'	CRIMP TERMINAL (3680M SERIES)
REV.	REVISION RECORD	DATE			